

UNIVERSITY OF CAMBRIDGE INTERNATIONAL EXAMINATIONS  
General Certificate of Education  
Advanced Subsidiary Level and Advanced Level

**PHYSICS**

**9702/03**

Paper 3 Practical Test

May/June 2004

CONFIDENTIAL INSTRUCTIONS

**1 hour 15 minutes**

**Great care should be taken that any confidential information given does not reach the candidates either directly or indirectly.**

This document consists of 7 printed pages and 1 blank page.



**Instructions for preparing apparatus**

These instructions detail the apparatus required for the experiment in this paper. A summary of the questions that will be presented to the candidates is included, to allow the Physics teacher to test the apparatus appropriately. No access is permitted to the Question Paper in advance of the examination session.

It is assumed that the ordinary apparatus of a Physics laboratory will be available.

**Instructions for the Practical Physics Supervisor**

Candidates should be informed that, if they find themselves in real difficulty, they may ask the Supervisor for practical assistance but that the extent of this assistance will be reported to the Examiner, who may make a deduction of marks.

The Supervisor should complete the report form on pages 7 and 8 and enclose it in the envelope containing the answers of the candidates. A note of any help given to, or any particular difficulties experienced by, a candidate should also be enclosed, especially if the Examiner would be unable to discover these from the written answers.

It is assumed that candidates will provide themselves with such standard items as a 30 cm rule, a pair of compasses, a  $0^\circ$  to  $180^\circ$  protractor, a set square and a calculator.

Squared paper should be available.

Whenever a stopwatch or stopclock is specified, candidates should be advised, in advance, that they may, if they wish, use quartz wristwatches with stopwatch facilities.

**Question 1**

Candidates will take readings of the extension of a spring as a suspended mass is lowered into a beaker of water.

**Apparatus requirements (per candidate)**

2 stands, bosses and clamps.

50 cm rule.

30 cm clear plastic rule.

Paper clip of approximate length 3 cm.

50 g mass holder.

Set of five 50 g masses which can be added to the 50 g mass holder to give a total mass of 300 g. The masses should all have the same diameter.

Vernier callipers (to be used to measure the diameter of a 50 g mass). If there is an insufficient number of callipers for candidates to use one each, then it is permissible for candidates to share one between four. Supervisors may have to instruct candidates when to make this measurement.

250 ml glass beaker containing about 200 ml of water. Supervisors must ensure that the depth of water is sufficient to cover the masses when the mass holder plus the other five masses are lowered into the water.

Expendable steel spring (e.g. Philip Harris catalogue number A41397.)

2 triangular pointers labelled 'A' and 'B'. The pointer shown full scale in Fig. 1.1 was found to be suitable. It may be made from thick card or plastic.

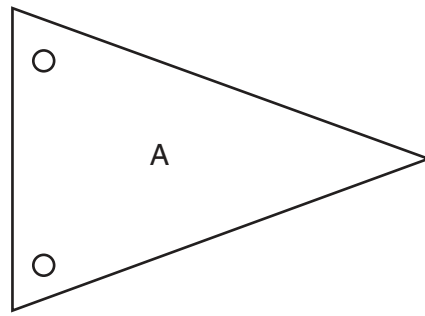

**Fig. 1.1**

The pointers must have holes at the top and bottom so that the paper clip, mass holder and spring can be attached without difficulty. The arrangement is shown in Fig. 1.2.

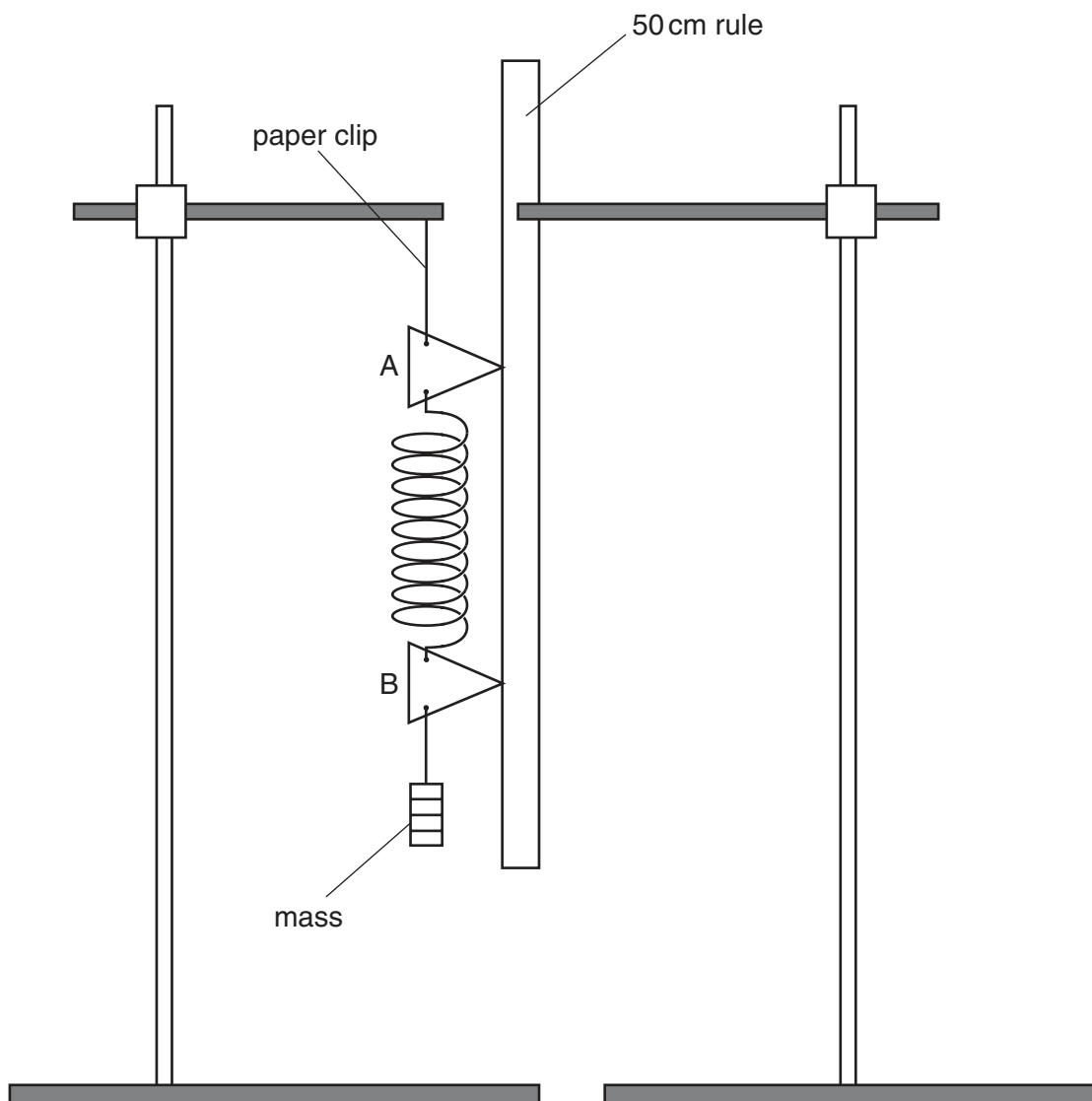

**Fig. 1.2**

The apparatus should not be assembled prior to use by the candidates.

**Information required by Examiners**

Extension of the spring when a load of 0.98 N is added.

Diameter of one of the 50 g masses.



This form should be completed and sent to the Examiner with the scripts.

## REPORT ON PRACTICAL PHYSICS

General Certificate of Education Advanced Subsidiary Level and Advanced Level

May/June Session 2004

### General

The Supervisor is invited to give details, on the reverse of this form, of any difficulties experienced by particular candidates, giving names and index numbers. These should include reference to:

- (a) accidents to apparatus or materials;
- (b) any other information that is likely to assist the examiner, especially if this cannot be discovered in the scripts;
- (c) any help given to a candidate.

Other cases of individual hardship, e.g. illness, disability, should be reported direct to CIE on the normal 'Special Consideration Form'.

In cases of faulty apparatus (not arising from a candidate's mishandling) which prevent the required readings being taken, the following action is permissible.

The Invigilator – in consultation with the Physics teacher responsible for preparing the examination – may allow extra time to give the candidate a fair opportunity to perform the experiment as if the fault had not been present. The candidate should use a spare copy of the Question Paper when the fault has been rectified or when working with a second set of apparatus. The Invigilator is asked to provide CIE with details of such cases of time compensation (a copy being enclosed with the scripts), especially

- (i) the candidate's name and index number,
- (ii) the extra time allowed,
- (iii) notes on the nature of the fault, the action taken to rectify the difficulty and any other comments which would be helpful to the Examiner in making a fair assessment of the candidate's work during the practical examination.



**Information required**

Extension of the spring when a load of 0.98 N is added =

Diameter of one of the 50 g masses =

A list, by name and index number, of candidates requiring help, with details of help provided.

**Declaration** (to be signed by the Principal)

The preparation of this practical examination has been carried out so as to maintain fully the security of the examination.

Signed .....

Centre Number .....

Name of Centre .....

